

DEPARTMENT OF SOCIAL WELFARE AND DEVELOPMENT FIELD OFFICE V
 Regional Center Site, Rawis, Legazpi City, Albay
REQUEST FOR QUOTATION

Company Name: _____
 Company Address: _____
 Contact No.: _____
 PhilGEPS Certificate No.: _____

P.R. No. NF 2503-0222
 Date: March 25, 2025
 Mode of Procurement: Small Value Procurement (53.9)
 TIN: _____

Please quote your lowest government price for the following item(s) specified below. Check/tick the "COMPLY" box if bidder complies with the specifications. A quotation containing unchecked/unticked "COMPLY" boxes would be automatically rated as "FAILED".

ITEM NO.	QTY.	UNIT	ITEM DESCRIPTION AND SPECIFICATIONS	Kindly CHECK to signify compliance to the specs.	UNIT COST	TOTAL COST
			LABOR AND MATERIALS FOR FABRICATION OF WOODEN CABINET FOR RSCC			
	3	unit	Wooden Cabinet 1.0m x 0.50 m x 0.80 m (LxWxH) Wooden cabinet Solid wood mahogany with 9 pull out drawers painted finish (see attached drawings for strict reference)	<input type="checkbox"/> Comply <input type="checkbox"/> Comply <input type="checkbox"/> Comply <input type="checkbox"/> Comply		
<i>Page 1 of 1</i>						
Approved Budget for the Contract:					PHP 79,380.00	

IMPORTANT REMINDERS:

- Price quotation/s must be valid for a period of 30 days from the date of submission.
- DELIVERY PERIOD: 30 working days upon the receipt of Purchase Order**
- PLACE OF DELIVERY: DSWD FO V, Rawis, Legazpi City.**
- The project shall be AWARDED:** (a) as one contract (b) separate contract per lot (c) separate contract per item
- TERM OF PAYMENT: **CHARGED ACCOUNT**, unless specified. 30-60 days from the receipt of Statement of Account / Billing.
- LIQUIDATED DAMAGES: **One-Tenth Of One Percent (0.001) of the cost of the unperformed portion of the contract for every day of delay.** Once the cumulative amount of liquidated damages reaches ten percent (10%) of the amount of the contract, the DSWD FOV **may rescind or terminate the contract**, without prejudice to other courses of action and remedies available under the circumstances.
- The Supplier/Contractor acknowledges and agrees that any acts falling under section 65 (Offenses and Penalties) and Section 69 (Imposition of Administrative Penalties and Blacklisting) of the Implementing Rules and Regulations (IRR) of Republic Act No. 9184 (Government Procurement Reform Act), as well as other relevant procurement laws and regulations, shall subject the Supplier/Contractor to blacklisting, administrative, civil, and/or criminal liabilities in accordance with applicable laws and regulations.
- Required documents to submit:
 - PhilGEPS Certification Number
 - Valid Mayor's or Business Permit
- As a condition for AWARD, you will be required to submit the following documents:
 - Omnibus Sworn Statement
 - _____
- For any clarifications, you may contact the BAC Secretariat through **procurement.fo5@dswd.gov.ph** or **0910-017-0818**
- Submit your quotation duly signed by you or your duly authorized representative not later than the deadline on _____

KIMBERLEE G. LANUZA
 AO II/Procurement Section Head

 Signature Over Printed Name of Canvasser

 Signature Over Printed Name of Bidder

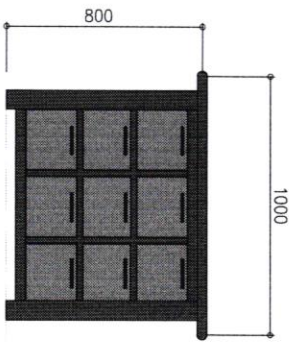

FRONT VIEW
SCALE 1:100

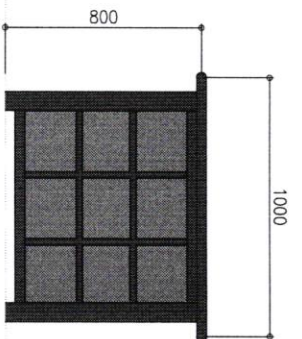

REAR VIEW
SCALE 1:100

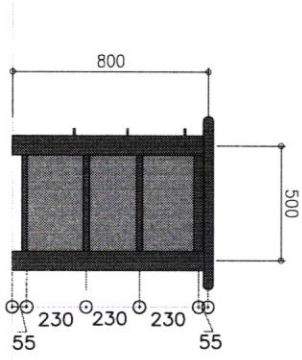

LEFT SIDE VIEW
SCALE 1:100

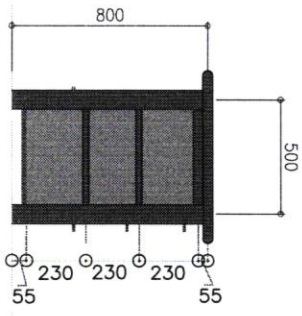

RIGHT SIDE VIEW
SCALE 1:100

FABRICATION OF SOLID WOODEN
CABINET W/ 9 PULL OUT DRAWERS

A
A1

SCALE

1:100